



Low Noise/Low Power/2-Wire Bus

X9418

Dual Digitally Controlled Potentiometers (XDCP™)

FEATURES

- Two potentiometers in one package
- 2-wire serial interface
- Register oriented format
 - Direct Read/Write Wiper Position
 - Store as many as Four Positions per Potentiometer
- Power supplies
 - $V_{CC} = 2.7V$ to $5.5V$
 - $V+ = 2.7V$ to $5.5V$
 - $V- = -2.7V$ to $-5.5V$
- Low power CMOS
 - Standby current $< 1\mu A$
 - Ideal for Battery Operated Applications
- High reliability
 - Endurance—100,000 Data Changes per Bit per Register
 - Register Data Retention—100 years
- 8-bytes of nonvolatile memory
- $10K\Omega$ resistor array
- Resolution: 64 taps each potentiometer
- 24-pin plastic DIP, 24-lead TSSOP and 24-lead SOIC packages

DESCRIPTION

The X9418 integrates two digitally controlled potentiometers (XDCP) on a monolithic CMOS integrated microcircuit.

The digitally controlled potentiometer is implemented using 63 resistive elements in a series array. Between each element are tap points connected to the wiper terminal through switches. The position of the wiper on the array is controlled by the user through the 2-wire bus interface. Each potentiometer has associated with it a volatile Wiper Counter Register (WCR) and 4 nonvolatile Data Registers (DR0:DR3) that can be directly written to and read by the user. The contents of the WCR controls the position of the wiper on the resistor array through the switches. Power up recalls the contents of DR0 to the WCR.

The XDCP can be used as a three-terminal potentiometer or as a two-terminal variable resistor in a wide variety of applications including control, parameter adjustments, and signal processing.

BLOCK DIAGRAM

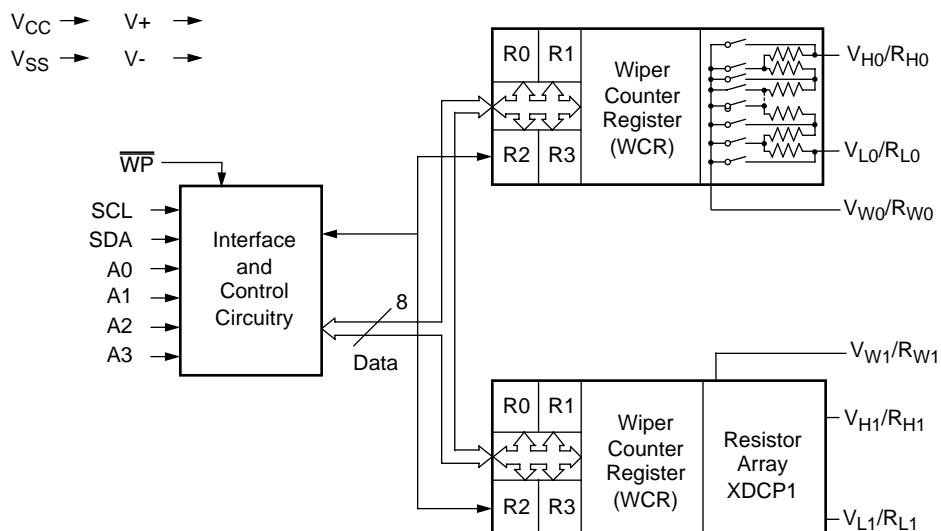

X9418

PIN DESCRIPTIONS

Host Interface Pins

Serial Clock (SCL)

The SCL input is used to clock data into and out of the X9418.

Serial Data (SDA)

SDA is a bidirectional pin used to transfer data into and out of the device. It is an open drain output and may be wire-ORed with any number of open drain or open collector outputs. An open drain output requires the use of a pull-up resistor. For selecting typical values, refer to the guidelines for calculating typical values on the bus pull-up resistors graph.

Device Address (A₀–A₃)

The Address inputs are used to set the least significant 4 bits of the 8-bit slave address. A match in the slave address serial data stream must be made with the Address input in order to initiate communication with the X9418. A maximum of 16 devices may occupy the 2-wire serial bus.

Potentiometer Pins

V_H/R_H (V_{H0}/R_{H0}–V_{H1}/R_{H1}), V_L/R_L (V_{L0}/R_{L0}–V_{L1}/R_{L1})

The V_H/R_H and V_L/R_L inputs are equivalent to the terminal connections on either end of a mechanical potentiometer.

V_W/R_W (V_{W0}/R_{W0}–V_{W1}/R_{W1})

The wiper outputs are equivalent to the wiper output of a mechanical potentiometer.

Hardware Write Protect Input (\overline{WP})

The \overline{WP} pin when low prevents nonvolatile writes to the Data Registers.

Analog Supplies V+, V-

The Analog Supplies V+, V- are the supply voltages for the XDCP analog section.

PIN CONFIGURATION

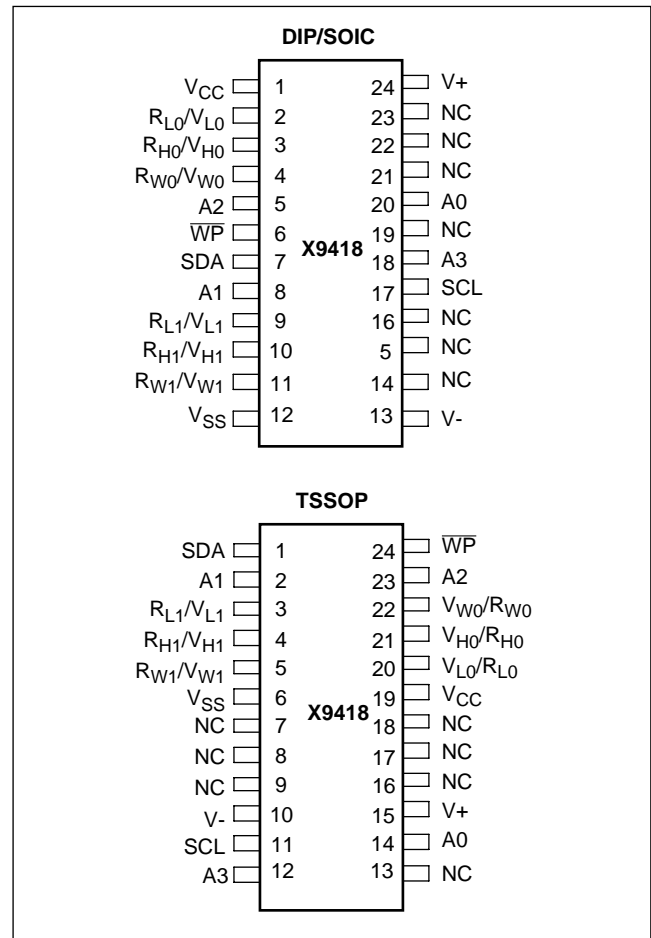

PIN NAMES

| Symbol | Description |
|--|---|
| SCL | Serial Clock |
| SDA | Serial Data |
| A ₀ -A ₃ | Device Address |
| V _{H0} /R _{H0} -V _{H1} /R _{H1} , V _{L0} /R _{L0} -V _{L1} /R _{L1} | Potentiometer Pins (terminal equivalent) |
| V _{W0} /R _{W0} -V _{W1} /R _{W1} | Potentiometer Pins (wiper equivalent) |
| \overline{WP} | Hardware Write Protection |
| V+, V- | Analog Supplies |
| V _{CC} | System Supply Voltage |
| V _{SS} | System Ground |
| NC | No Connection |

X9418

PRINCIPLES OF OPERATION

The X9418 is a highly integrated microcircuit incorporating two resistor arrays and their associated registers and counters and the serial interface logic providing direct communication between the host and the XDCP potentiometers.

Serial Interface

The X9418 supports a bidirectional bus oriented protocol. The protocol defines any device that sends data onto the bus as a transmitter and the receiving device as the receiver. The device controlling the transfer is a master and the device being controlled is the slave. The master will always initiate data transfers and provide the clock for both transmit and receive operations. Therefore, the X9418 will be considered a slave device in all applications.

Clock and Data Conventions

Data states on the SDA line can change only during SCL LOW periods (t_{LOW}). SDA state changes during SCL HIGH are reserved for indicating start and stop conditions.

Start Condition

All commands to the X9418 are preceded by the start condition, which is a HIGH to LOW transition of SDA while SCL is HIGH (t_{HIGH}). The X9418 continuously monitors the SDA and SCL lines for the start condition and will not respond to any command until this condition is met.

Stop Condition

All communications must be terminated by a stop condition, which is a LOW to HIGH transition of SDA while SCL is HIGH.

Acknowledge

Acknowledge is a software convention used to provide a positive handshake between the master and slave devices on the bus to indicate the successful receipt of data. The transmitting device, either the master or the slave, will release the SDA bus after transmitting eight bits. The master generates a ninth clock cycle and during this period the receiver pulls the SDA line LOW to acknowledge that it successfully received the eight bits of data.

The X9418 will respond with an acknowledge after recognition of a start condition and its slave address and once again after successful receipt of the command byte. If the command is followed by a data byte the X9418 will respond with a final acknowledge.

Array Description

The X9418 is comprised of two resistor arrays. Each array contains 63 discrete resistive segments that are connected in series. The physical ends of each array are equivalent to the fixed terminals of a mechanical potentiometer (V_H/R_H and V_L/R_L inputs).

At both ends of each array and between each resistor segment is a CMOS switch connected to the wiper (V_W/R_W) output. Within each individual array only one switch may be turned on at a time. These switches are controlled by the Wiper Counter Register (WCR). The six bits of the WCR are decoded to select, and enable, one of sixty-four switches.

The WCR may be written directly, or it can be changed by transferring the contents of one of four associated Data Registers into the WCR. These Data Registers and the WCR can be read and written by the host system.

Device Addressing

Following a start condition the master must output the address of the slave it is accessing. The most significant four bits of the slave address are the device type identifier (refer to Figure 1 below). For the X9418 this is fixed as 0101[B].

Figure 1. Slave Address

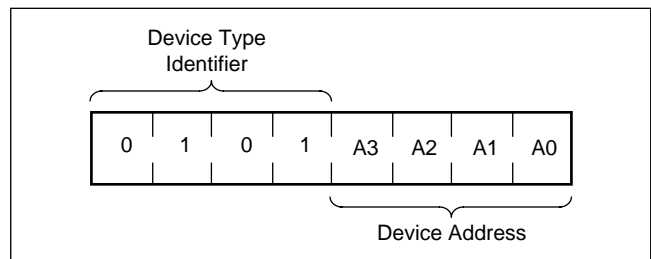

The next four bits of the slave address are the device address. The physical device address is defined by the state of the A_0 – A_3 inputs. The X9418 compares the serial data stream with the address input state; a successful compare of all four address bits is required for the X9418 to respond with an acknowledge. The A_0 – A_3 inputs can be actively driven by CMOS input signals or tied to V_{CC} or V_{SS} .

X9418

Acknowledge Polling

The disabling of the inputs, during the internal nonvolatile write operation, can be used to take advantage of the typical 5ms EEPROM write cycle time. Once the stop condition is issued to indicate the end of the nonvolatile write command the X9418 initiates the internal write cycle. ACK polling can be initiated immediately. This involves issuing the start condition followed by the device slave address. If the X9418 is still busy with the write operation no ACK will be returned. If the X9418 has completed the write operation an ACK will be returned, and the master can then proceed with the next operation.

Flow 1. ACK Polling Sequence

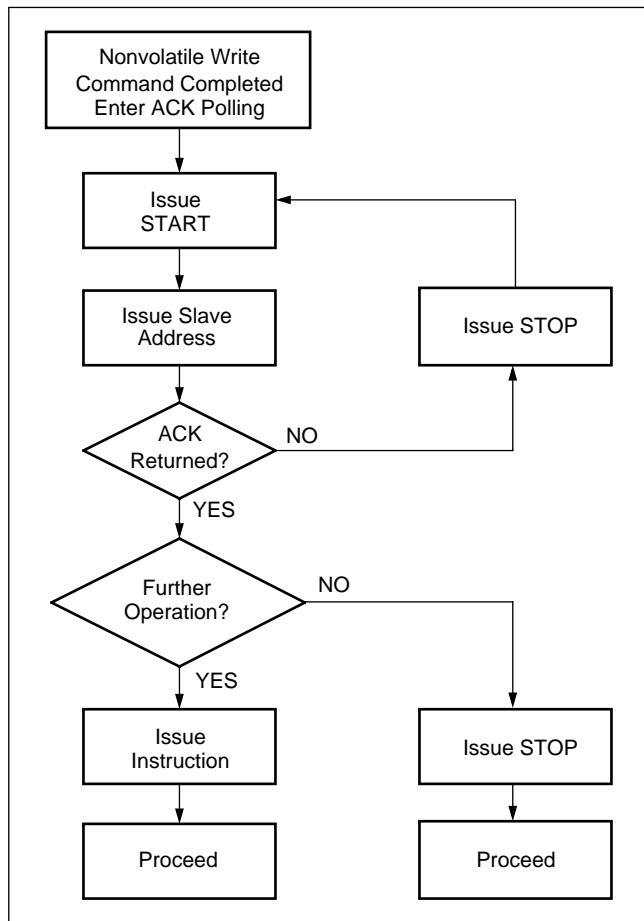

Instruction Structure

The next byte sent to the X9418 contains the instruction and register pointer information. The four most significant bits are the instruction. The next four bits

point to one of the two pots and when applicable they point to one of four associated registers. The format is shown below in Figure 2.

Figure 2. Instruction Byte Format

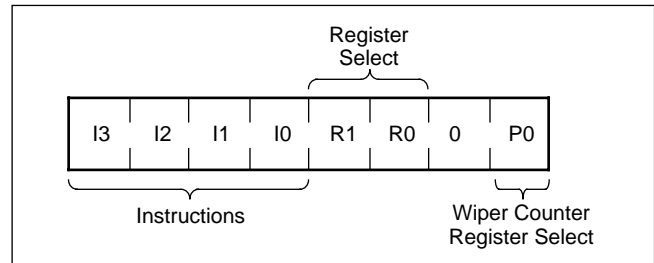

The four high order bits define the instruction. The next two bits (R1 and R0) select one of the four registers that is to be acted upon when a register oriented instruction is issued. The last bits (P0) select which one of the two potentiometers is to be affected by the instruction. Bit 1 is defined to be 0.

Four of the nine instructions end with the transmission of the instruction byte. The basic sequence is illustrated in Figure 3. These two-byte instructions exchange data between the wiper counter register and one of the data registers. A transfer from a Data Register to a Wiper Counter Register is essentially a write to a static RAM. The response of the wiper to this action will be delayed t_{WRL} . A transfer from the wiper counter register (current wiper position), to a Data Register is a write to nonvolatile memory and takes a minimum of t_{WR} to complete. The transfer can occur between one of the two potentiometers and one of its associated registers; or it may occur globally, wherein the transfer occurs between both of the potentiometers and one of their associated registers.

Four instructions require a three-byte sequence to complete. These instructions transfer data between the host and the X9418; either between the host and one of the Data Registers or directly between the host and the wiper counter register. These instructions are: Read Wiper Counter Register (read the current wiper position of the selected pot), write Wiper Counter Register (change current wiper position of the selected pot), read Data Register (read the contents of the selected nonvolatile register) and write Data Register (write a new value to the selected Data Register). The sequence of operations is shown in Figure 4.

Figure 3. Two-Byte Instruction Sequence

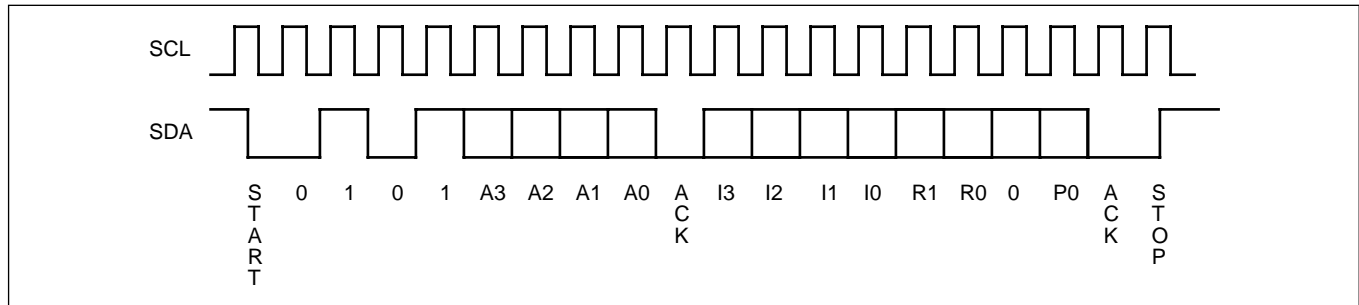

The Increment/Decrement command is different from the other commands. Once the command is issued and the X9418 has responded with an acknowledge, the master can clock the selected wiper up and/or down in one segment steps; thereby, providing a fine tuning capability to the host. For each SCL clock pulse (t_{HIGH}) while SDA is HIGH, the selected wiper will move one

resistor segment towards the V_H/R_H terminal. Similarly, for each SCL clock pulse while SDA is LOW, the selected wiper will move one resistor segment towards the V_L/R_L terminal. A detailed illustration of the sequence and timing for this operation are shown in Figures 5 and 6 respectively.

Table 1. Instruction Set

| Instruction | Instruction Set | | | | | | | | Operation |
|--|-----------------|----------------|----------------|----------------|----------------|----------------|----------------|----------------|---|
| | I ₃ | I ₂ | I ₁ | I ₀ | R ₁ | R ₀ | P ₁ | P ₀ | |
| Read Wiper Counter Register | 1 | 0 | 0 | 1 | 0 | 0 | 0 | 1/0 | Read the contents of the Wiper Counter Register pointed to by P ₀ |
| Write Wiper Counter Register | 1 | 0 | 1 | 0 | 0 | 0 | 0 | 1/0 | Write new value to the Wiper Counter Register pointed to by P ₀ |
| Read Data Register | 1 | 0 | 1 | 1 | 1/0 | 1/0 | 0 | 1/0 | Read the contents of the Data Register pointed to by P ₀ and R ₁ –R ₀ |
| Write Data Register | 1 | 1 | 0 | 0 | 1/0 | 1/0 | 0 | 1/0 | Write new value to the Data Register pointed to by P ₀ and R ₁ –R ₀ |
| XFR Data Register to Wiper Counter Register | 1 | 1 | 0 | 1 | 1/0 | 1/0 | 0 | 1/0 | Transfer the contents of the Data Register pointed to by P ₀ and R ₁ –R ₀ to its associated Wiper Counter Register |
| XFR Wiper Counter Register to Data Register | 1 | 1 | 1 | 0 | 1/0 | 1/0 | 0 | 1/0 | Transfer the contents of the Wiper Counter Register pointed to by P ₀ to the Data Register pointed to by R ₁ –R ₀ |
| Global XFR Data Registers to Wiper Counter Registers | 0 | 0 | 0 | 1 | 1/0 | 1/0 | 0 | 0 | Transfer the contents of the Data Registers pointed to by R ₁ –R ₀ of both pots to their respective Wiper Counter Registers |
| Global XFR Wiper Counter Registers to Data Register | 1 | 0 | 0 | 0 | 1/0 | 1/0 | 0 | 0 | Transfer the contents of both Wiper Counter Registers to their respective data Registers pointed to by R ₁ –R ₀ of both pots |
| Increment/Decrement Wiper Counter Register | 0 | 0 | 1 | 0 | 0 | 0 | 0 | 1/0 | Enable Increment/decrement of the Wiper Counter Register pointed to by P ₀ |

Note: (7) 1/0 = data is one or zero

Figure 4. Three-Byte Instruction Sequence

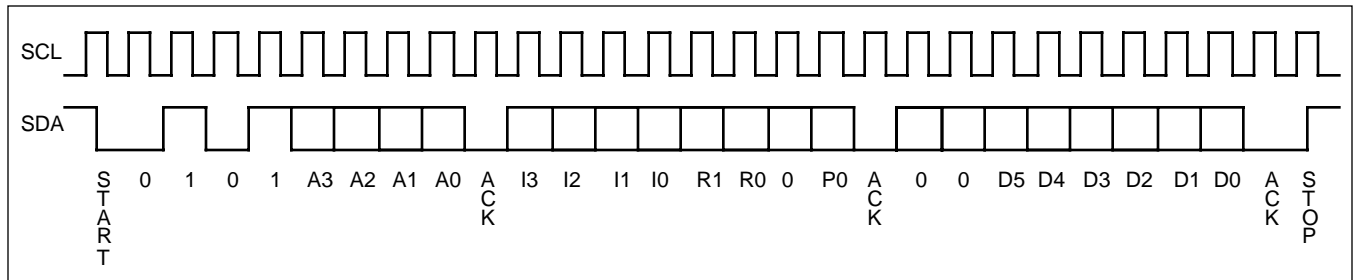

Figure 5. Increment/Decrement Instruction Sequence

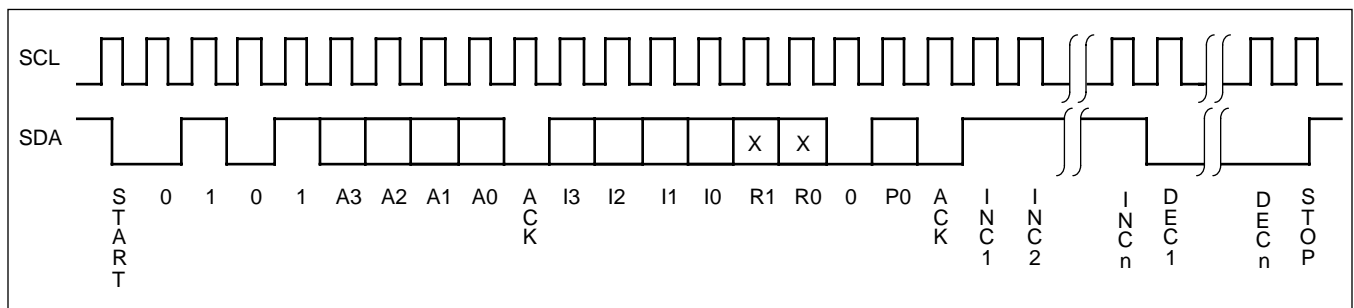

Figure 6. Increment/Decrement Timing Limits

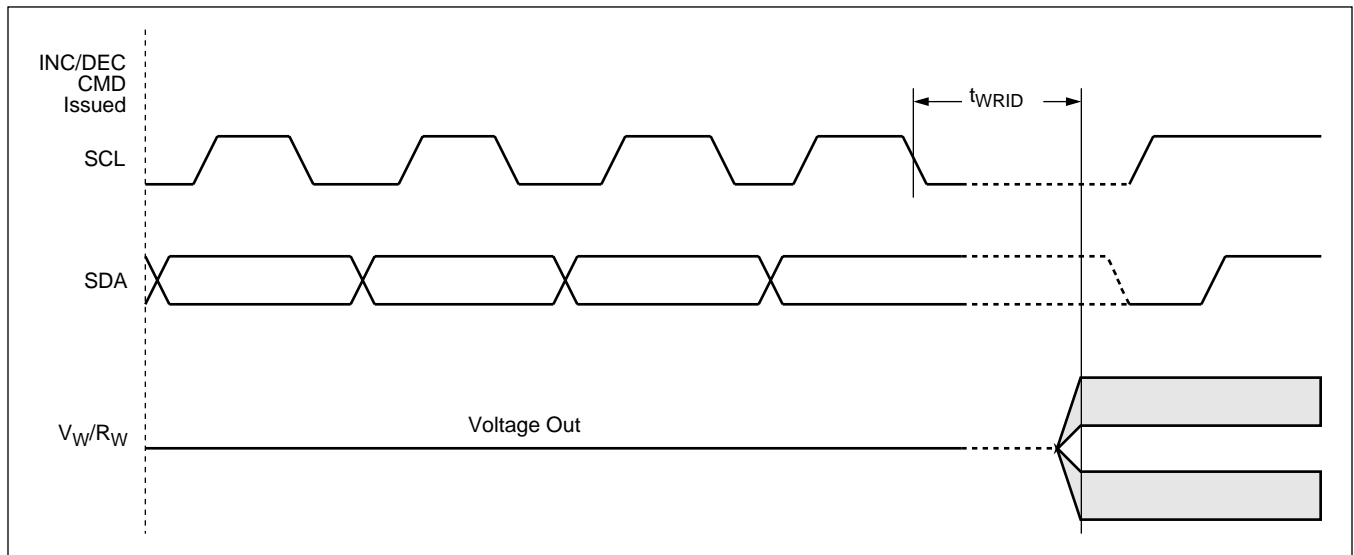

Figure 7. Acknowledge Response from Receiver

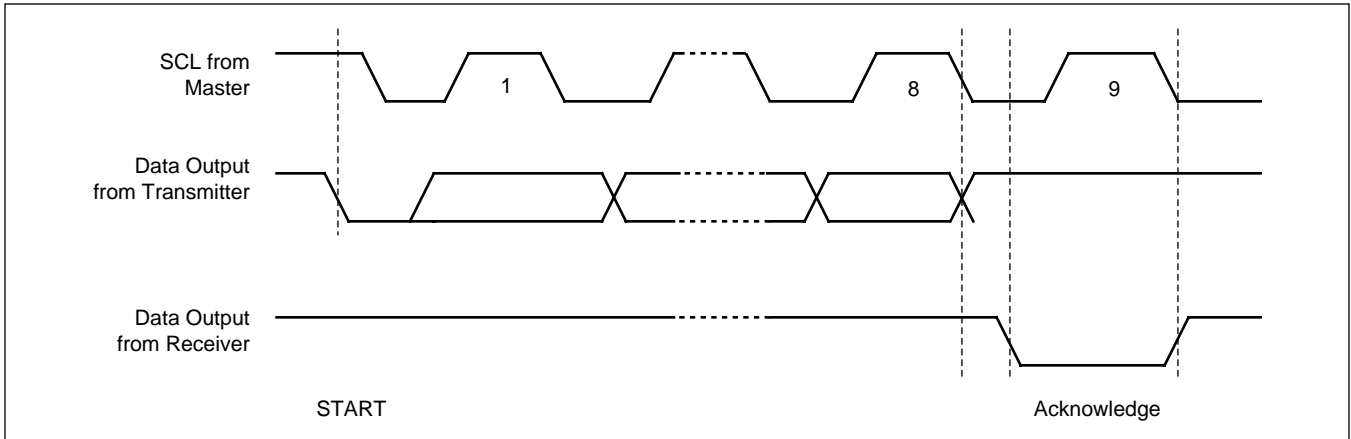
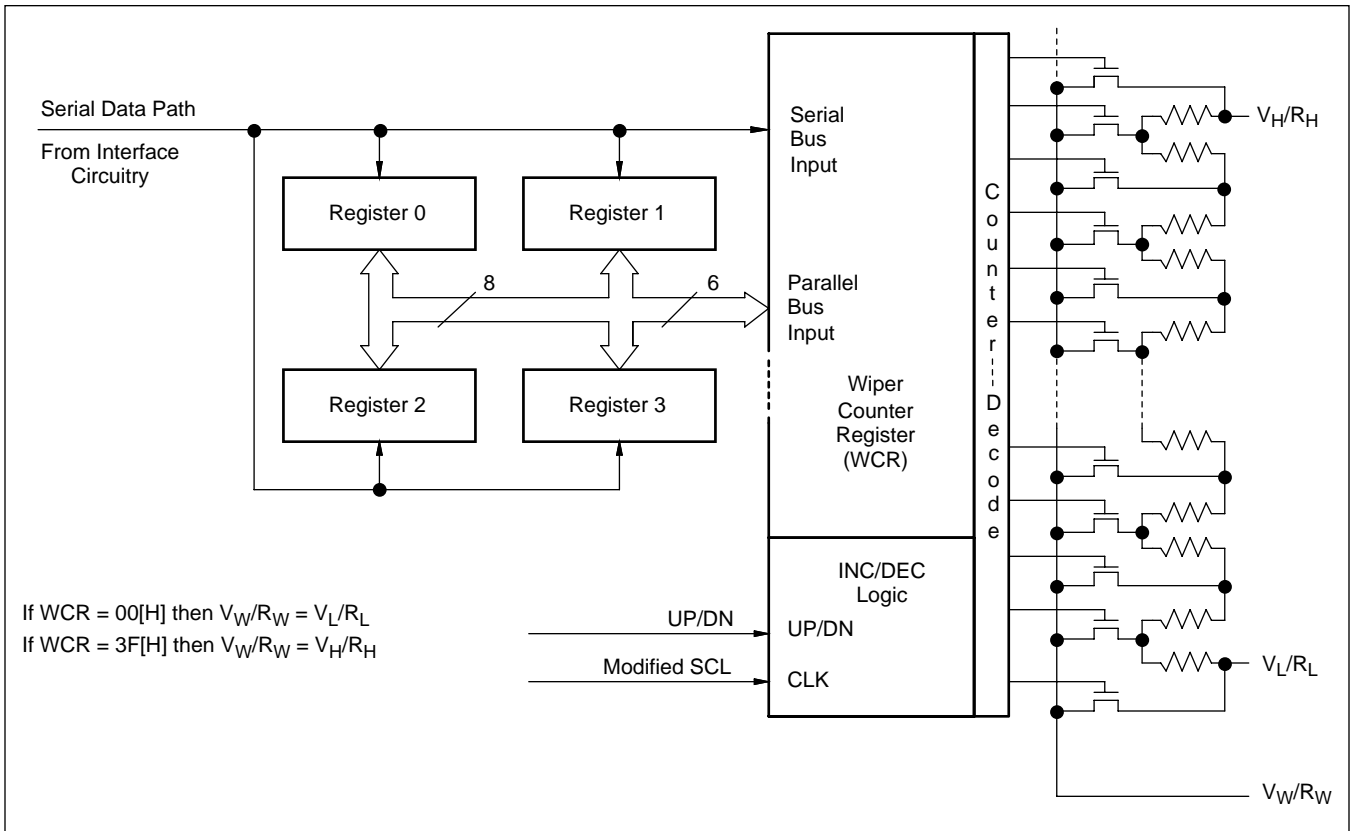

Figure 8. Detailed Potentiometer Block Diagram



X9418

DETAILED OPERATION

Both XDCP potentiometers share the serial interface and share a common architecture. Each potentiometer has a Wiper Counter Register and four Data Registers. A detailed discussion of the register organization and array operation follows.

Wiper Counter Register

The X9418 contains two wiper counter registers, one for each XDCP potentiometer. The Wiper Counter Register can be envisioned as a 6-bit parallel and serial load counter with its outputs decoded to select one of sixty-four switches along its resistor array. The contents of the WCR can be altered in four ways: it may be written directly by the host via the write Wiper Counter Register instruction (serial load); it may be written indirectly by transferring the contents of one of four associated Data Registers via the XFR Data Register instruction (parallel load); it can be modified one step at a time by the Increment/Decrement instruction. Finally, it is loaded with the contents of its Data Register zero (DR0) upon power-up.

The WCR is a volatile register; that is, its contents are lost when the X9418 is powered-down. Although the register is automatically loaded with the value in DR0 upon power-up, it should be noted this may be different from the value present at power-down.

Data Registers

Each potentiometer has four nonvolatile Data Registers. These can be read or written directly by the host and data can be transferred between any of the four Data Registers and the Wiper Counter Register. It should be noted all operations changing data in one of these registers is a nonvolatile operation and will take a maximum of 10ms.

If the application does not require storage of multiple settings for the potentiometer, these registers can be used as regular memory locations that could possibly store system parameters or user preference data.

Register Descriptions

Data Registers, (6-Bit), Nonvolatile

| D5 | D4 | D3 | D2 | D1 | D0 |
|-------|----|----|----|----|-------|
| NV | NV | NV | NV | NV | NV |
| (MSB) | | | | | (LSB) |

Four 6-bit Data Registers for each XDCP. (eight 6-bit registers in total).

- {D5~D0}: These bits are for general purpose not volatile data storage or for storage of up to four different wiper values. The contents of Data Register 0 are automatically moved to the Wiper Counter Register on power-up.

Wiper Counter Register, (6-Bit), Volatile

| WP5 | WP4 | WP3 | WP2 | WP1 | WP0 |
|-------|-----|-----|-----|-----|-------|
| V | V | V | V | V | V |
| (MSB) | | | | | (LSB) |

One 6-bit wiper counter register for each XDCP. (Four 6-bit registers in total.)

- {D5~D0}: These bits specify the wiper position of the respective XDCP. The Wiper Counter Register is loaded on power-up by the value in Data Register 0. The contents of the WCR can be loaded from any of the other Data Register or directly. The contents of the WCR can be saved in a DR.

X9418

Instruction Format

- Notes:** (1) "MACK"/"SACK": stands for the acknowledge sent by the master/slave.
 (2) "A3 – A0": stands for the device addresses sent by the master.
 (3) "X": indicates that it is a "0" for testing purpose but physically it is a "don't care" condition.
 (4) "I": stands for the increment operation, SDA held high during active SCL phase (high).
 (5) "D": stands for the decrement operation, SDA held low during active SCL phase (high).

Read Wiper Counter Register (WCR)

| S T A R T | device type identifier | | | | device addresses | | | | S A C K | instruction opcode | | | | wiper addresses | | | | S A C K | wiper position (sent by slave on SDA) | | | | | | | M A C K | S T O P |
|-----------------------|------------------------|---|---|---|------------------|----|----|----|------------------|--------------------|---|---|---|-----------------|---|---|----|------------------|--|---|-------------|-------------|-------------|-------------|-------------|------------------|------------------|
| | 0 | 1 | 0 | 1 | A3 | A2 | A1 | A0 | | 1 | 0 | 0 | 1 | 0 | 0 | 0 | P0 | | 0 | 0 | W P 5 | W P 4 | W P 3 | W P 2 | W P 1 | | |
| | | | | | | | | | | | | | | | | | | | | | | | | | | | |

Write Wiper Counter Register (WCR)

| S T A R T | device type identifier | | | | device addresses | | | | S A C K | instruction opcode | | | | wiper addresses | | | | S A C K | wiper position (sent by master on SDA) | | | | | | | S A C K | S T O P |
|-----------------------|------------------------|---|---|---|------------------|----|----|----|------------------|--------------------|---|---|---|-----------------|---|---|----|------------------|---|---|-------------|-------------|-------------|-------------|-------------|------------------|------------------|
| | 0 | 1 | 0 | 1 | A3 | A2 | A1 | A0 | | 1 | 0 | 1 | 0 | 0 | 0 | 0 | P0 | | 0 | 0 | W P 5 | W P 4 | W P 3 | W P 2 | W P 1 | | |
| | | | | | | | | | | | | | | | | | | | | | | | | | | | |

Read Data Register (DR)

| S T A R T | device type identifier | | | | device addresses | | | | S A C K | instruction opcode | | | | wiper addresses | | | | S A C K | wiper position/data (sent by slave on SDA) | | | | | | | M A C K | S T O P |
|-----------------------|------------------------|---|---|---|------------------|----|----|----|------------------|--------------------|---|---|---|-----------------|----|---|----|------------------|---|---|-------------|-------------|-------------|-------------|-------------|------------------|------------------|
| | 0 | 1 | 0 | 1 | A3 | A2 | A1 | A0 | | 1 | 0 | 1 | 1 | R1 | R0 | 0 | P0 | | 0 | 0 | W P 5 | W P 4 | W P 3 | W P 2 | W P 1 | | |
| | | | | | | | | | | | | | | | | | | | | | | | | | | | |

Write Data Register (DR)

| S T A R T | device type identifier | | | | device addresses | | | | S A C K | instruction opcode | | | | wiper addresses | | | | S A C K | wiper position/data (sent by master on SDA) | | | | | | | S A C K | S T O P | HIGH-VOLTAGE WRITE CYCLE | |
|-----------------------|------------------------|---|---|---|------------------|----|----|----|------------------|--------------------|---|---|---|-----------------|----|---|----|------------------|--|---|-------------|-------------|-------------|-------------|-------------|------------------|------------------|-----------------------------|-------------|
| | 0 | 1 | 0 | 1 | A3 | A2 | A1 | A0 | | 1 | 1 | 0 | 0 | R1 | R0 | 0 | P0 | | 0 | 0 | W P 5 | W P 4 | W P 3 | W P 2 | W P 1 | | | | W P 0 |
| | | | | | | | | | | | | | | | | | | | | | | | | | | | | | |

XFR Data Register (DR) to Wiper Counter Register (WCR)

| S T A R T | device type identifier | | | | device addresses | | | | S A C K | instruction opcode | | | | wiper addresses | | | | S A C K | S T O P | | | | | | | |
|-----------------------|------------------------|---|---|---|------------------|----|----|----|------------------|--------------------|---|---|---|-----------------|----|---|----|------------------|------------------|--|--|--|--|--|--|--|
| | 0 | 1 | 0 | 1 | A3 | A2 | A1 | A0 | | 1 | 1 | 0 | 1 | R1 | R0 | 0 | P0 | | | | | | | | | |
| | | | | | | | | | | | | | | | | | | | | | | | | | | |

X9418

XFR Wiper Counter Register (WCR) to Data Register (DR)

| START | device type identifier | | | | device addresses | | | | SACK | instruction opcode | | | | wiper addresses | | | | SACK | STOP | HIGH-VOLTAGE WRITE CYCLE |
|-------|------------------------|---|---|---|------------------|----|----|----|------|--------------------|---|---|---|-----------------|----|---|----|------|------|--------------------------|
| | 0 | 1 | 0 | 1 | A3 | A2 | A1 | A0 | | 1 | 1 | 1 | 0 | R1 | R0 | 0 | P0 | | | |
| | 0 | 1 | 0 | 1 | A3 | A2 | A1 | A0 | | 1 | 1 | 1 | 0 | R1 | R0 | 0 | P0 | | | |

Increment/Decrement Wiper Counter Register (WCR)

| START | device type identifier | | | | device addresses | | | | SACK | instruction opcode | | | | wiper addresses | | | | increment/decrement (sent by master on SDA) | | | | STOP | | | | |
|-------|------------------------|---|---|---|------------------|----|----|----|------|--------------------|---|---|---|-----------------|---|---|----|---|-----|---|---|------|---|-----|-----|-----|
| | 0 | 1 | 0 | 1 | A3 | A2 | A1 | A0 | | 0 | 0 | 1 | 0 | 0 | 0 | 0 | P0 | I/D | I/D | . | . | | . | . | I/D | I/D |
| | 0 | 1 | 0 | 1 | A3 | A2 | A1 | A0 | | 0 | 0 | 1 | 0 | 0 | 0 | 0 | P0 | I/D | I/D | . | . | . | . | I/D | I/D | |

Global XFR Data Register (DR) to Wiper Counter Register (WCR)

| START | device type identifier | | | | device addresses | | | | SACK | instruction opcode | | | | wiper addresses | | | | SACK | STOP | |
|-------|------------------------|---|---|---|------------------|----|----|----|------|--------------------|---|---|---|-----------------|----|---|---|------|------|--|
| | 0 | 1 | 0 | 1 | A3 | A2 | A1 | A0 | | 0 | 0 | 0 | 1 | R1 | R0 | 0 | 0 | | | |
| | 0 | 1 | 0 | 1 | A3 | A2 | A1 | A0 | | 0 | 0 | 0 | 1 | R1 | R0 | 0 | 0 | | | |

Global XFR Wiper Counter Register (WCR) to Data Register (DR)

| START | device type identifier | | | | device addresses | | | | SACK | instruction opcode | | | | wiper addresses | | | | SACK | STOP | HIGH-VOLTAGE WRITE CYCLE |
|-------|------------------------|---|---|---|------------------|----|----|----|------|--------------------|---|---|---|-----------------|----|---|---|------|------|--------------------------|
| | 0 | 1 | 0 | 1 | A3 | A2 | A1 | A0 | | 1 | 0 | 0 | 0 | R1 | R0 | 0 | 0 | | | |
| | 0 | 1 | 0 | 1 | A3 | A2 | A1 | A0 | | 1 | 0 | 0 | 0 | R1 | R0 | 0 | 0 | | | |

SYMBOL TABLE

| WAVEFORM | INPUTS | OUTPUTS |
|----------|-----------------------------|-------------------------------|
| | Must be steady | Will be steady |
| | May change from Low to High | Will change from Low to High |
| | May change from High to Low | Will change from High to Low |
| | Don't Care: Changes Allowed | Changing: State Not Known |
| | N/A | Center Line is High Impedance |

Guidelines for Calculating Typical Values of Bus Pull-Up Resistors

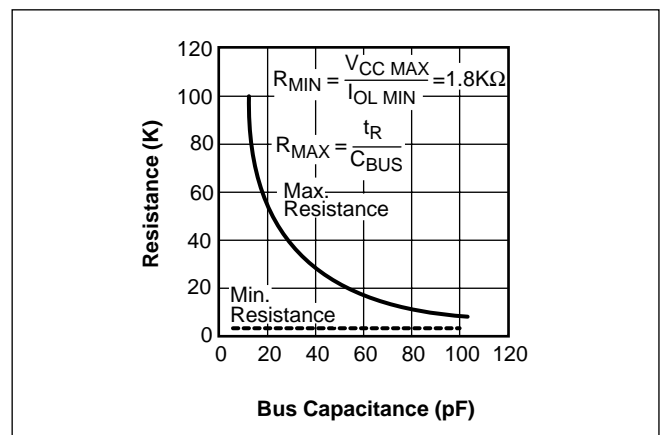

X9418

ABSOLUTE MAXIMUM RATINGS

| | |
|--|-----------------|
| Temperature under bias | -65°C to +135°C |
| Storage temperature | -65°C to +150°C |
| Voltage on SDA, SCL or any address input with respect to V_{SS} | -1V to +7V |
| Voltage on V+ (referenced to V_{SS}) | 10V |
| Voltage on V- (referenced to V_{SS}) | -10V |
| (V+) – (V-) | 12V |
| Any V_H/R_H | V+ |
| Any V_L/R_L | V- |
| Lead temperature (soldering, 10 seconds) | 300°C |
| I_W (10 seconds) | ±12mA |

COMMENT

Stresses above those listed under “Absolute Maximum Ratings” may cause permanent damage to the device. This is a stress rating only; functional operation of the device (at these or any other conditions above those listed in the operational sections of this specification) is not implied. Exposure to absolute maximum rating conditions for extended periods may affect device reliability.

RECOMMENDED OPERATING CONDITIONS

| Temperature | Min. | Max. |
|-------------|-------|-------|
| Commercial | 0°C | +70°C |
| Industrial | -40°C | +85°C |

| Device | Supply Voltage (V_{CC}) Limits |
|-----------|------------------------------------|
| X9418 | 5V ±10% |
| X9418-2.7 | 2.7V to 5.5V |

ANALOG CHARACTERISTICS (Over recommended operating conditions unless otherwise stated.)

| Symbol | Parameter | Limits | | | | Test Conditions |
|---------------|---|-----------|----------|------|-------------------|---|
| | | Min. | Typ. | Max. | Unit | |
| R_{TOTAL} | End to end resistance | | | ±20 | % | |
| | Power rating | | | 50 | mW | 25°C, each pot |
| I_W | Wiper current | | | ±6 | mA | |
| R_W | Wiper resistance | | 150 | 250 | Ω | Wiper current = ± 1mA, V_{CC} = 3V |
| | | | 40 | 100 | Ω | Wiper current = ± 1mA, V_{CC} = 3V |
| V+ | Voltage on V+ pin | X9418 | +4.5 | +5.5 | V | |
| | | X9418-2.7 | +2.7 | +5.5 | | |
| V- | Voltage on V- pin | X9418 | -5.5 | -4.5 | V | |
| | | X9418-2.7 | -5.5 | -2.7 | | |
| V_{TERM} | Voltage on any V_H/R_H or V_L/R_L pin | V- | | V+ | V | |
| | Noise | | -140 | | dBV | Ref: 1kHz |
| | Resolution ⁽⁴⁾ | | 1.6 | | % | |
| | Absolute linearity ⁽¹⁾ | | | ±1 | MI ⁽³⁾ | $V_{w(n)}(actual) - V_{w(n)}(expected)$ |
| | Relative linearity ⁽²⁾ | | | ±0.2 | MI ⁽³⁾ | $V_{w(n+1)} - [V_{w(n)} + MI]$ |
| | Temperature Coefficient of R_{TOTAL} | | ±300 | | ppm/°C | |
| | Ratiometric Temperature Coefficient | | | ±20 | ppm/°C | |
| $C_H/C_L/C_W$ | Potentiometer Capacitances | | 10/10/25 | | pF | See Circuit #3, Spice Macromodel |

X9418

D.C. OPERATING CHARACTERISTICS (Over the recommended operating conditions unless otherwise specified.)

| Symbol | Parameter | Limits | | | | Test Conditions |
|------------------|--|-----------------------|------|-----------------------|------|---|
| | | Min. | Typ. | Max. | Unit | |
| I _{CC1} | V _{CC} supply current (nonvolatile write) | | | 1 | mA | f _{SCL} = 400kHz, SDA = Open, Other Inputs = V _{SS} |
| I _{CC2} | V _{CC} supply current (move wiper, write, read) | | | 100 | μA | f _{SCL} = 400kHz, SDA = Open, Other Inputs = V _{SS} |
| I _{SB} | V _{CC} current (standby) | | | 1 | μA | SCL = SDA = V _{CC} , Addr. = V _{SS} |
| I _{LI} | Input leakage current | | | 10 | μA | V _{IN} = V _{SS} to V _{CC} |
| I _{LO} | Output leakage current | | | 10 | μA | V _{OUT} = V _{SS} to V _{CC} |
| V _{IH} | Input HIGH voltage | V _{CC} × 0.7 | | V _{CC} × 0.5 | V | |
| V _{IL} | Input LOW voltage | -0.5 | | V _{CC} × 0.1 | V | |
| V _{OL} | Output LOW voltage | | | 0.4 | V | I _{OL} = 3mA |

- Notes:** (1) Absolute linearity is utilized to determine actual wiper voltage versus expected voltage as determined by wiper position when used as a potentiometer.
 (2) Relative linearity is utilized to determine the actual change in voltage between two successive tap positions when used as a potentiometer. It is a measure of the error in step size.
 (3) MI = RTOT/63 or (V_H—V_L)/63, single pot
 (4) Max. = all four arrays cascaded together, Typical = individual array resolutions.

ENDURANCE AND DATA RETENTION

| Parameter | Min. | Unit |
|-------------------|---------|-----------------------------------|
| Minimum endurance | 100,000 | Data changes per bit per register |
| Data retention | 100 | Years |

CAPACITANCE

| Symbol | Test | Max. | Unit | Test Conditions |
|---------------------------------|---|------|------|-----------------------|
| C _{I/O} ⁽⁵⁾ | Input/output capacitance (SDA) | 8 | pF | V _{I/O} = 0V |
| C _{IN} ⁽⁵⁾ | Input capacitance (A0, A1, A2, A3, and SCL) | 6 | pF | V _{IN} = 0V |

POWER-UP TIMING

| Symbol | Parameter | Min. | Typ. | Max. | Unit |
|---------------------------------|---|------|------|------|--------|
| t _{PUR} ⁽⁶⁾ | Power-up to initiation of read operation | | | 1 | ms |
| t _{PWW} ⁽⁶⁾ | Power-up to initiation of write operation | | | 5 | ms |
| t _{RVCC} | V _{CC} Power up ramp rate | 0.2 | | 50 | V/msec |

POWER-UP AND POWER-DOWN

There are no restrictions on the power-up or power-down sequencing of the bias supplies V_{CC}, V₊, and V₋ provided that all three supplies reach their final values within 1msec of each other. However, at all times, the voltages on the potentiometer pins must be less than V₊ and more than V₋. The recall of the wiper position from nonvolatile memory is not in effect until all supplies reach their final value.

- Notes:** (5) This parameter is periodically sampled and not 100% tested
 (6) t_{PUR} and t_{PWW} are the delays required from the time the third (last) power supply (V_{CC}, V₊ or V₋) is stable until the specific instruction can be issued. These parameters are periodically sampled and not 100% tested.

X9418

A.C. TEST CONDITIONS

| | |
|-------------------------------|--|
| Input pulse levels | $V_{CC} \times 0.1$ to $V_{CC} \times 0.9$ |
| Input rise and fall times | 10ns |
| Input and output timing level | $V_{CC} \times 0.5$ |

EQUIVALENT A.C. LOAD CIRCUIT

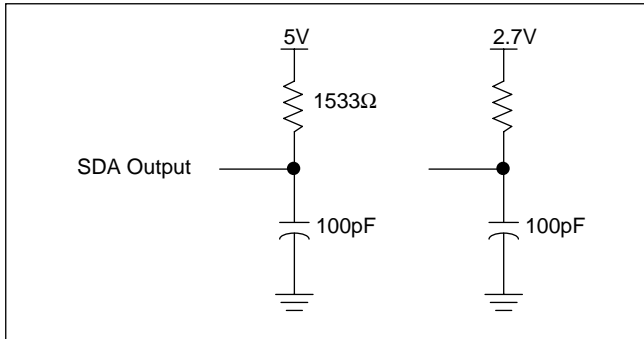

Circuit #3 SPICE Macro Model

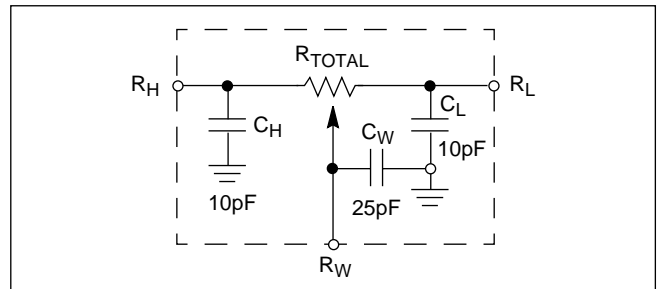

AC TIMING (over recommended operating conditions)

| Symbol | Parameter | Min. | Max. | Unit |
|--------------|---|------|------|------|
| f_{SCL} | Clock frequency | | 400 | kHz |
| t_{CYC} | Clock cycle time | 2500 | | ns |
| t_{HIGH} | Clock high time | 600 | | ns |
| t_{LOW} | Clock low time | 1300 | | ns |
| $t_{SU:STA}$ | Start setup time | 600 | | ns |
| $t_{HD:STA}$ | Start hold time | 600 | | ns |
| $t_{SU:STO}$ | Stop setup time | 600 | | ns |
| $t_{SU:DAT}$ | SDA data input setup time | 100 | | ns |
| $t_{HD:DAT}$ | SDA data input hold time | 30 | | ns |
| t_R | SCL and SDA rise time | | 300 | ns |
| t_F | SCL and SDA fall time | | 300 | ns |
| t_{AA} | SCL low to SDA data output valid time | 100 | 900 | ns |
| t_{DH} | SDA data output hold time | 50 | | ns |
| T_I | Noise suppression time constant at SCL and SDA inputs | 50 | | ns |
| t_{BUF} | Bus free time (prior to any transmission) | 1300 | | ns |
| $t_{SU:WPA}$ | \overline{WP} , A0, A1, A2 and A3 setup time | 0 | | ns |
| $t_{HD:WPA}$ | \overline{WP} , A0, A1, A2 and A3 hold time | 0 | | ns |

X9418

HIGH-VOLTAGE WRITE CYCLE TIMING

| Symbol | Parameter | Typ. | Max. | Unit |
|----------|--|------|------|------|
| t_{WR} | High-voltage write cycle time (store instructions) | 5 | 10 | ms |

XDCP TIMING

| Symbol | Parameter | Min. | Max. | Unit |
|------------|---|------|------|---------|
| t_{WRPO} | Wiper response time after the third (last) power supply is stable | | 10 | μ s |
| t_{WRL} | Wiper response time after instruction issued (all load instructions) | | 10 | μ s |
| t_{WRID} | Wiper response time from an active SCL/SCK edge (increment/decrement instruction) | | 10 | μ s |

Note: (8) A device must internally provide a hold time of at least 300ns for the SDA signal in order to bridge the undefined region of the falling edge of SCL.

TIMING DIAGRAMS

START and STOP Timing

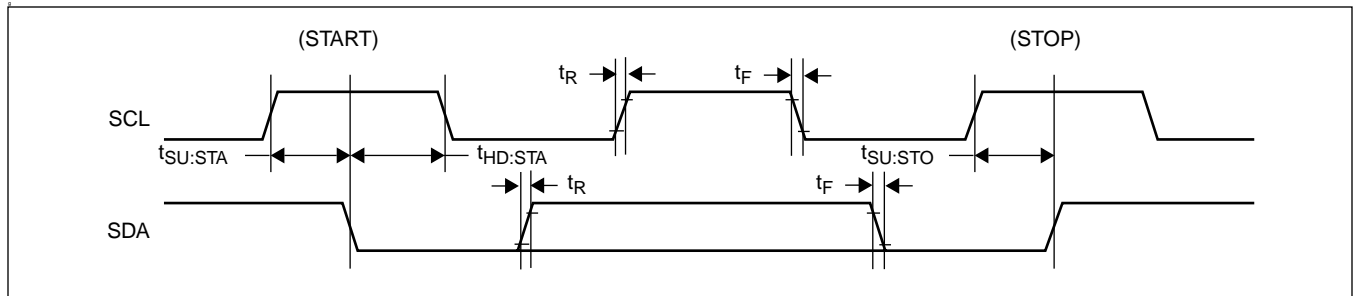

Input Timing

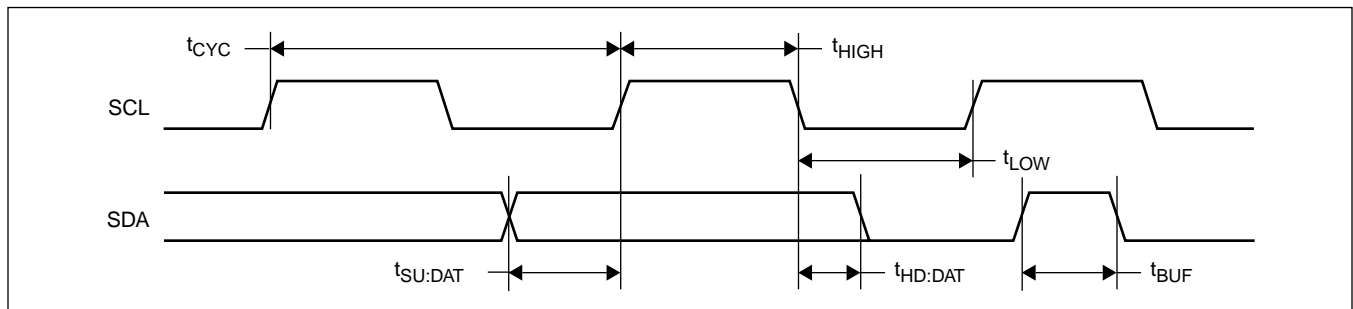

Output Timing

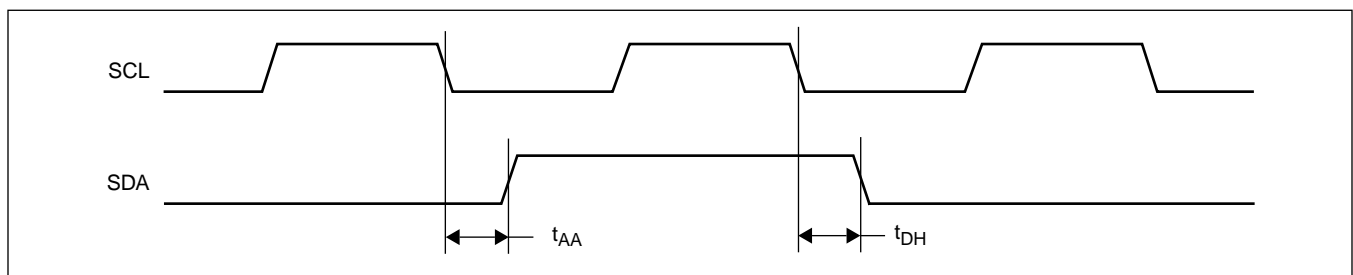

X9418

XDCP Timing (for All Load Instructions)

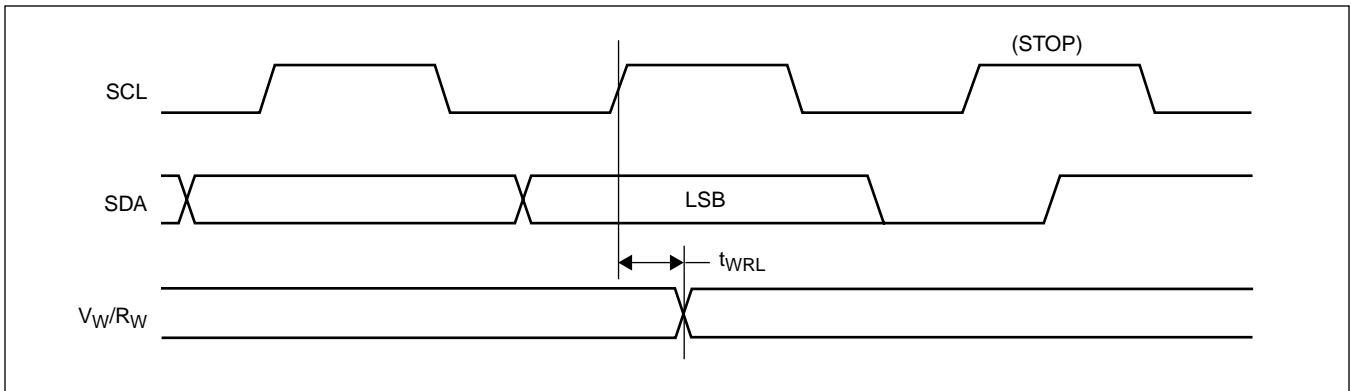

XDCP Timing (for Increment/Decrement Instruction)

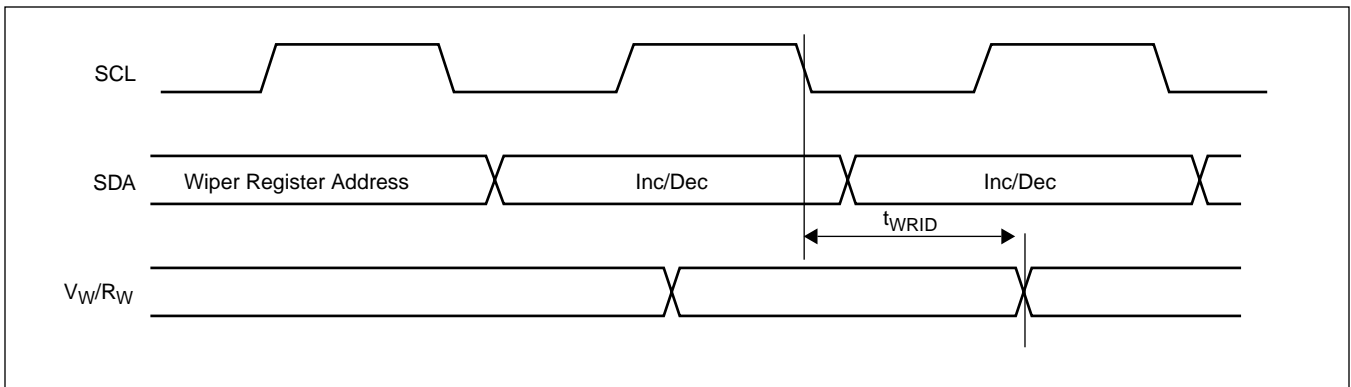

Write Protect and Device Address Pins Timing

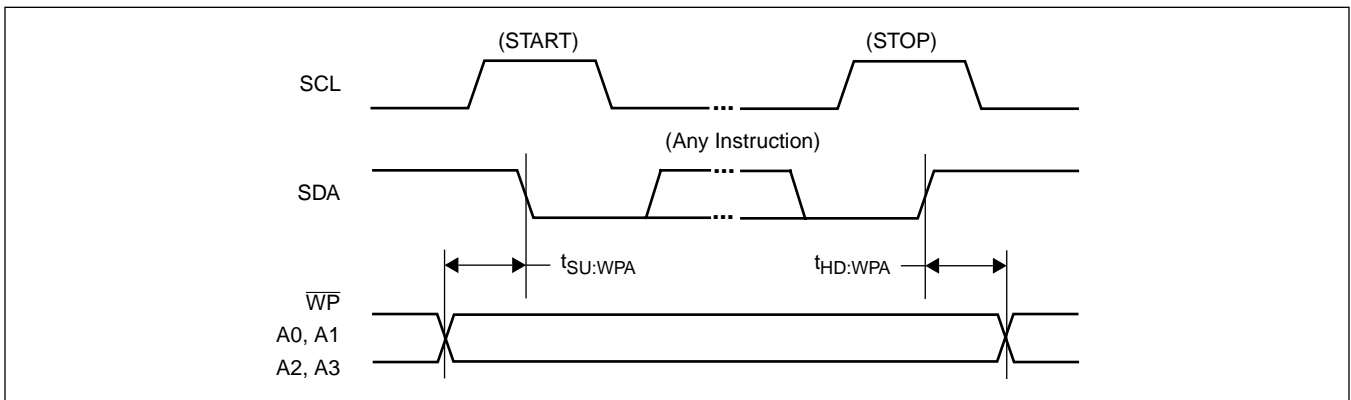

X9418

PACKAGING INFORMATION

24-Lead Plastic Dual In-Line Package Type P

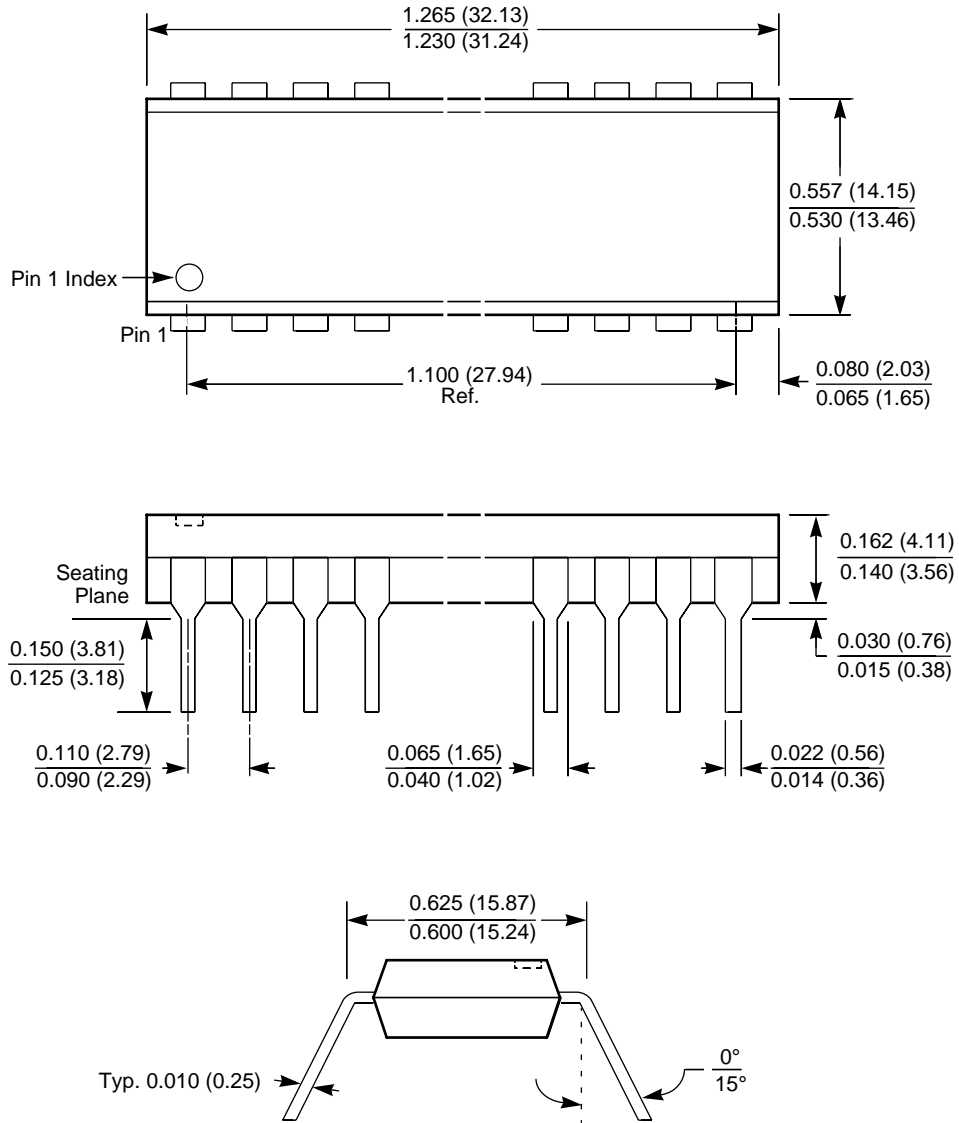

NOTE:

1. ALL DIMENSIONS IN INCHES (IN PARENTHESES IN MILLIMETERS)
2. PACKAGE DIMENSIONS EXCLUDE MOLDING FLASH

PACKAGING INFORMATION

24-Lead Plastic Small Outline Gull Wing Package Type S

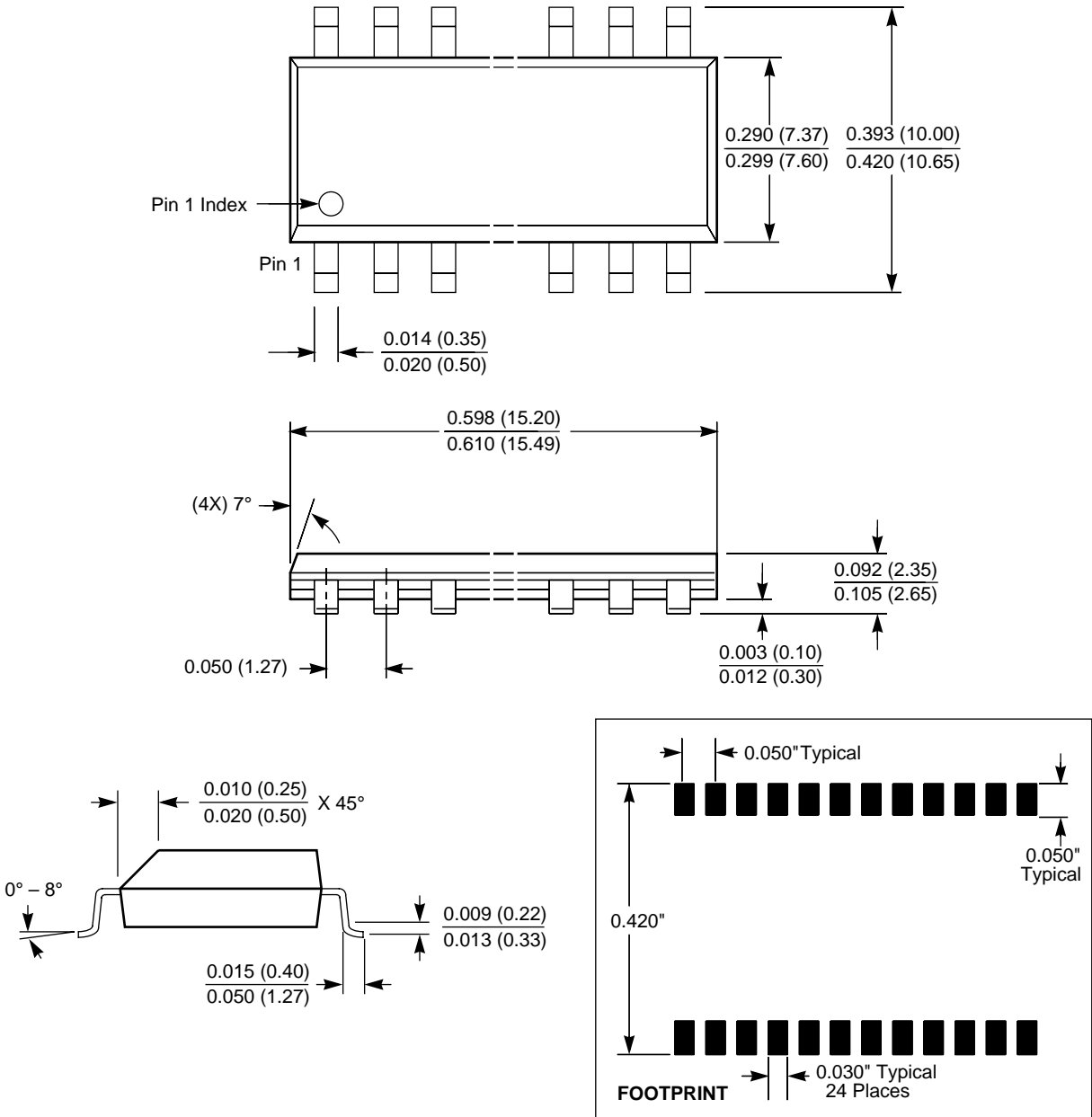

NOTE: ALL DIMENSIONS IN INCHES (IN PARENTHESES IN MILLIMETERS)

X9418

PACKAGING INFORMATION

24-Lead Plastic, TSSOP Package Type V

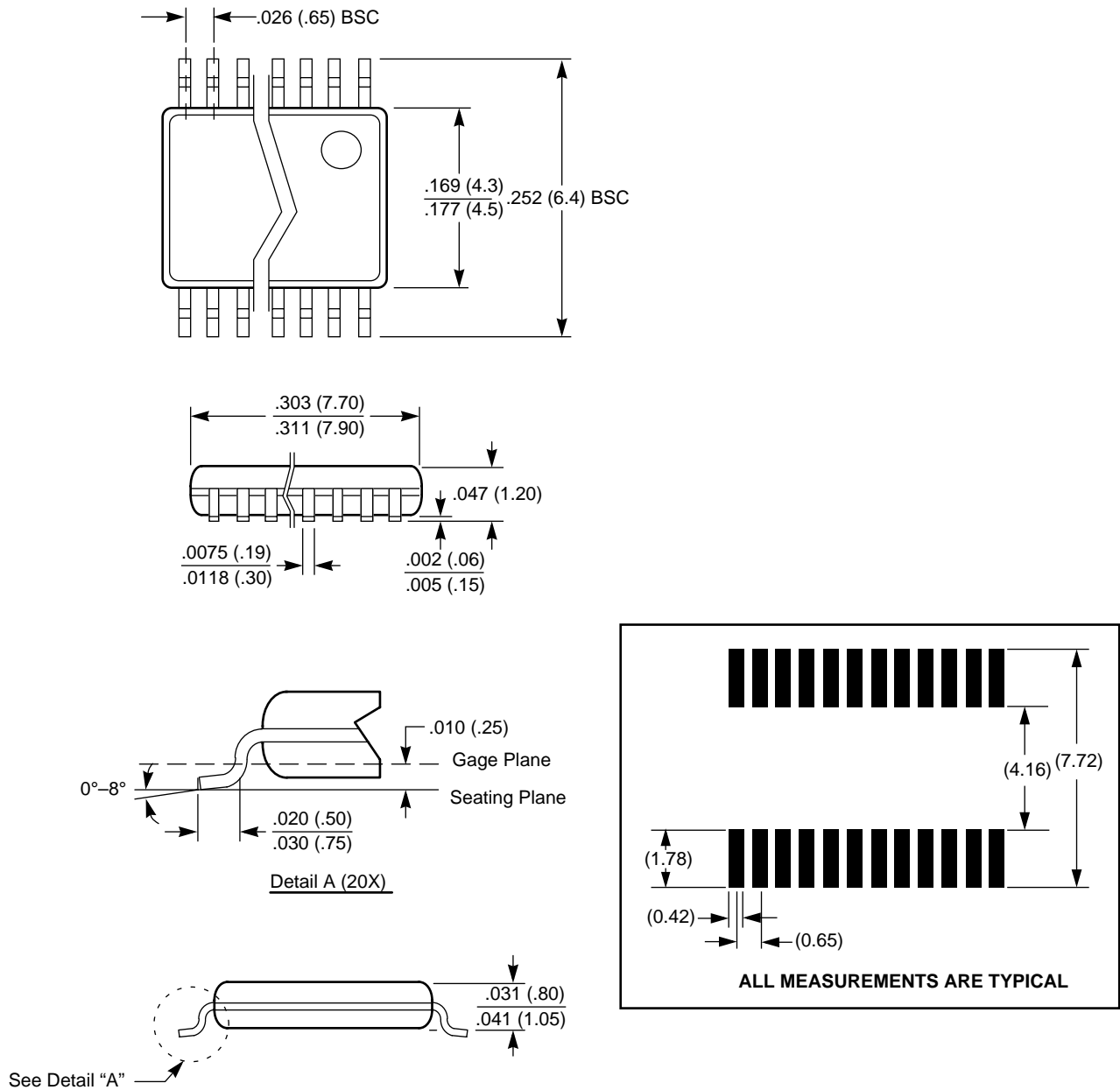

NOTE: ALL DIMENSIONS IN INCHES (IN PARENTHESES IN MILLIMETERS)

X9418

Ordering Information

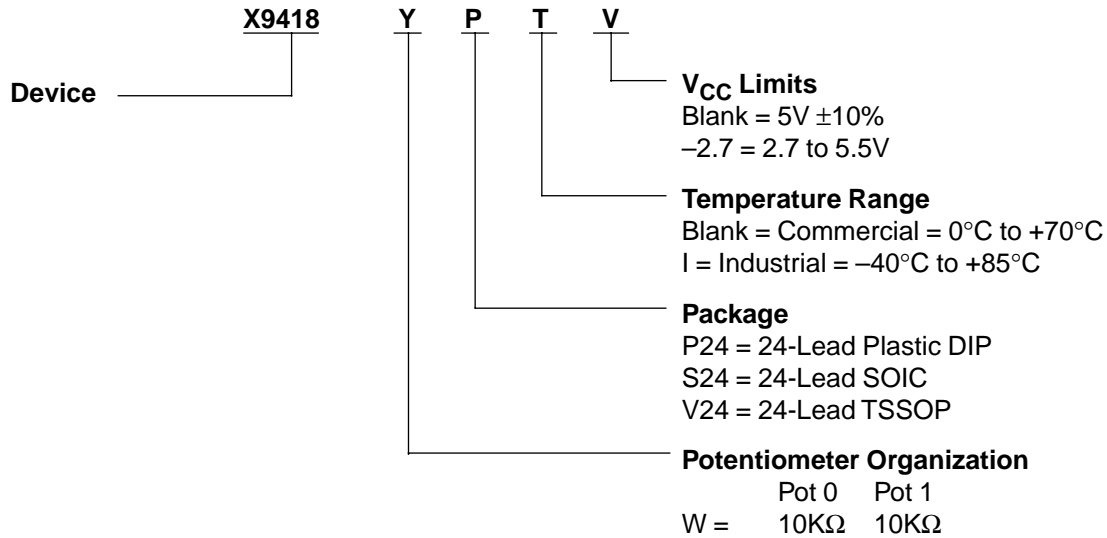

LIMITED WARRANTY

©Xicor, Inc. 2000 Patents Pending

Devices sold by Xicor, Inc. are covered by the warranty and patent indemnification provisions appearing in its Terms of Sale only. Xicor, Inc. makes no warranty, express, statutory, implied, or by description regarding the information set forth herein or regarding the freedom of the described devices from patent infringement. Xicor, Inc. makes no warranty of merchantability or fitness for any purpose. Xicor, Inc. reserves the right to discontinue production and change specifications and prices at any time and without notice.

Xicor, Inc. assumes no responsibility for the use of any circuitry other than circuitry embodied in a Xicor, Inc. product. No other circuits, patents, or licenses are implied.

TRADEMARK DISCLAIMER:

Xicor and the Xicor logo are registered trademarks of Xicor, Inc. AutoStore, Direct Write, Block Lock, SerialFlash, MPS, and XDCP are also trademarks of Xicor, Inc. All others belong to their respective owners.

U.S. PATENTS

Xicor products are covered by one or more of the following U.S. Patents: 4,326,134; 4,393,481; 4,404,475; 4,450,402; 4,486,769; 4,488,060; 4,520,461; 4,533,846; 4,599,706; 4,617,652; 4,668,932; 4,752,912; 4,829,482; 4,874,967; 4,883,976; 4,980,859; 5,012,132; 5,003,197; 5,023,694; 5,084,667; 5,153,880; 5,153,691; 5,161,137; 5,219,774; 5,270,927; 5,324,676; 5,434,396; 5,544,103; 5,587,573; 5,835,409; 5,977,585. Foreign patents and additional patents pending.

LIFE RELATED POLICY

In situations where semiconductor component failure may endanger life, system designers using this product should design the system with appropriate error detection and correction, redundancy and back-up features to prevent such an occurrence.

Xicor's products are not authorized for use in critical components in life support devices or systems.

1. Life support devices or systems are devices or systems which, (a) are intended for surgical implant into the body, or (b) support or sustain life, and whose failure to perform, when properly used in accordance with instructions for use provided in the labeling, can be reasonably expected to result in a significant injury to the user.
2. A critical component is any component of a life support device or system whose failure to perform can be reasonably expected to cause the failure of the life support device or system, or to affect its safety or effectiveness.